

TIMKEN

Installation Guide

Timken Quick-Flex[®] Coupling: Single-Ended Spacer

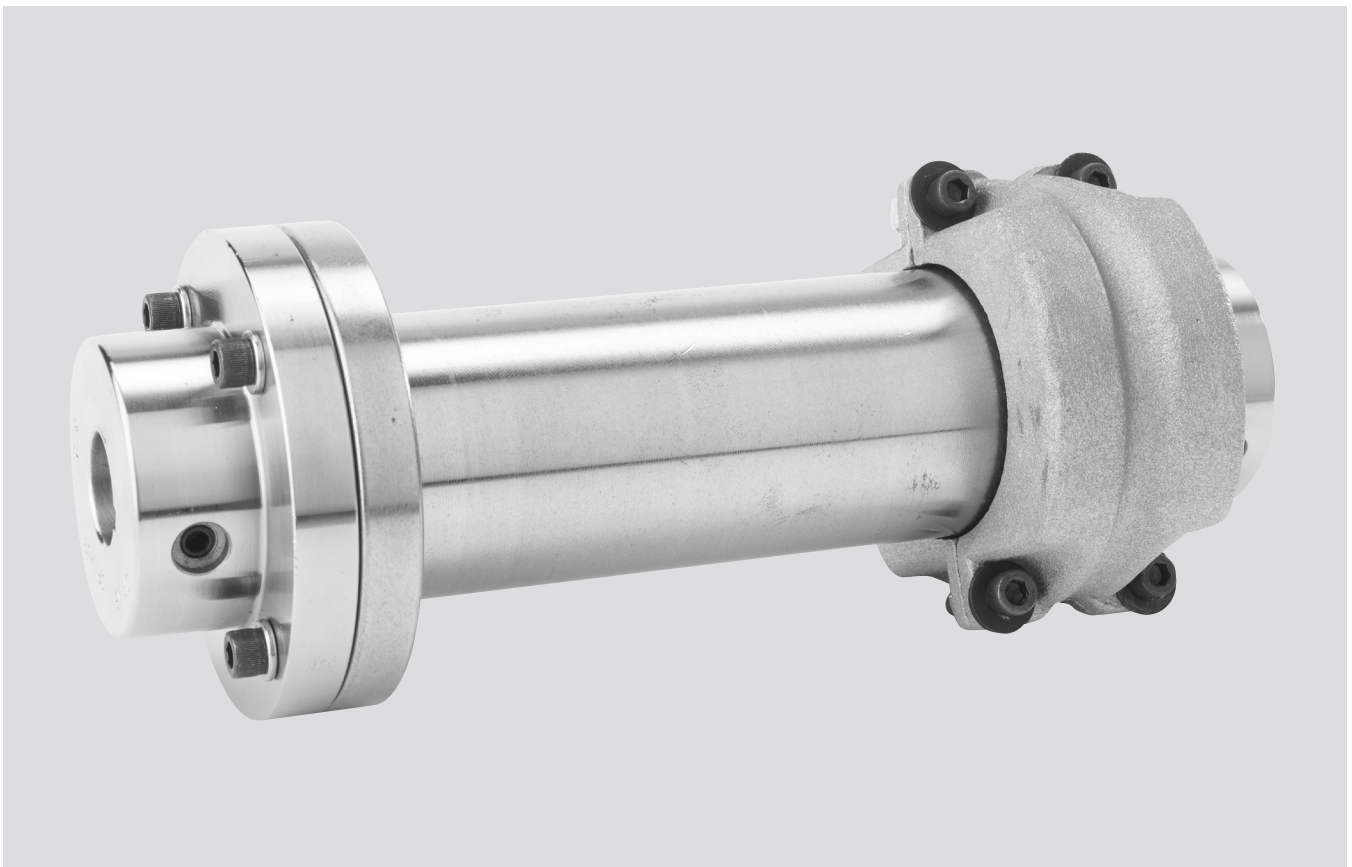

SINGLE-ENDED SPACER COUPLING INSTALLATION

Please complete the following steps to install Timken Quick-Flex single-ended spacer couplings.

You should have the following pieces before starting the job:

- One coupling hub
- One flanged hub
- One spacer body
- One insert
- One cover with included hardware

NOTE

It is critical to identify what style cover you are using, as this will change the hardware included, as well as the installation procedure. A mismatch between the coupling and the application may result in less than optimal performance.

There are four types of covers (fig. 1):

- **High-speed cover:** QF5 through QF175 use a standard snap ring to secure cover in place. QF250 and larger use eight bolts with lock washers.
- **Low-speed split cover:** This cover is free-floating and is located outside the shoulders of the two hubs. All sizes come with four bolts for securing the two halves together around the insert.
- **High-speed split cover:** This cover will be supplied in four pieces to fit over the spacer body. QF15 through QF250 use eight bolts around the rim to secure the two halves together, QF500 through QF1890 use 16 bolts, and QF3150 and larger use 20 bolts. QF250 and larger use eight bolts with lock washers to secure the cover to the hub.
- **High-performance split cover:** This cover is free-floating and is located on the insert with an internal radial groove. All sizes come with four socket-head cap screws for securing the two halves together around the insert.

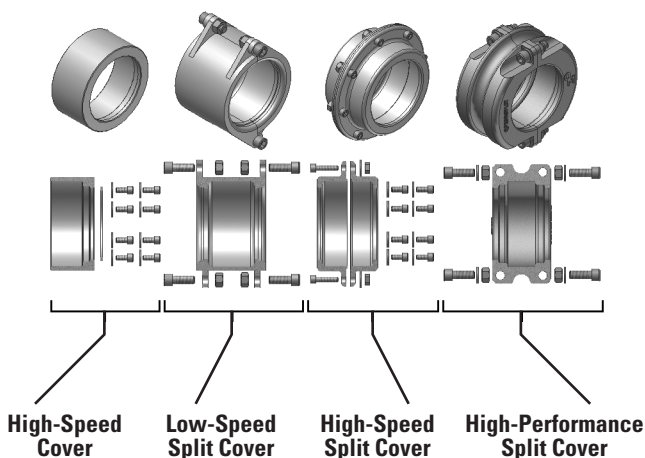

Fig. 1. Quick-Flex cover types and included hardware.

INSTALLATION

1. The Timken Quick-Flex single-ended spacer coupling should be oriented with the flanged hub on the drive shaft and the coupling hub with insert on the driven shaft (fig. 2).
2. Check the bore size of the coupling hub and flanged hub to the shafts. Ensure that they are the correct bore size to fit the application.
3. If the coupling does not fit easily, clean and deburr the shafts.
4. Identify cover style:
 - a. **If using a high-speed cover**, it should be placed on one of the shafts. If cover uses a snap ring, slide the snap ring down the shaft, then slide the cover onto shaft with the larger opening facing the shaft separation.
 - b. **If using a low-speed or high-performance split cover**, leave cover aside and continue to step 5.
 - c. **If using a high-speed split cover, QF250 and larger**, use bolts and washers to secure in place. In some instances, one or both vertically split pieces cover halves will also be split horizontally. The horizontally split half should be placed on the spacer body side. If both halves are split then splits should be aligned 90 degrees from each other when bolted together. Do not bolt to coupling hub until installation is complete.
5. Install the coupling hub. It should be mounted so the end of the shaft is flush with surface "A" as shown in fig. 2. It is acceptable for the shaft to extend past "A" as long as it is not past the teeth shown as "B."
6. Install the flanged hub using the spacer body and insert to locate the flanged hub on the drive shaft. This will set the hubs at the minimum hub gap (G_{Min}) dimension when the insert is tight between the coupling hub and spacer body, ensuring proper clearance. For specific G_{Min} and G_{Max} dimensions see table 2.
7. Tighten the flanged hub and coupling hub securely to the shafts using the set screws.
8. Check coupling for misalignment (table 3) and align as necessary.
9. Install the cover:
 - a. **High-speed cover:** Slide the cover over the coupling hub and insert until fully rested against the shoulder of the coupling hub. QF5 through QF175 use standard snap rings to hold the cover in place. QF250 and larger couplings use eight bolts and washers. Use the included hardware to secure the cover.
 - b. **Low-speed or high-performance split cover:** Place each half over the insert and secure using the four bolt/washer/nut hardware combinations supplied. For the high-performance split cover bolt tightening torque ratings, see table 1.
 - c. **High-speed split cover:** Match the four pieces into two complete cover halves using the flange face detail to distinguish the two halves. For QF250 and larger, make sure the cover half with the eight holes for mounting to the coupling hub is on the coupling hub side, not the spacer side. Bolt the four pieces together using the

supplied hardware, ensuring the splits in each half are rotated 90 degrees relative to each other. Install the bolts to secure the cover to the coupling hub.

- Ensure the four spacer body bolts through the flange are tight along with all other bolts and set screws.

NOTE

Standard hubs are supplied with a clearance fit and should slide onto the shaft without excessive force. If the hubs have been ordered with interference fit, then heat the coupling halves to approximately 300° C (572° F) before installing on shafts. If not heated properly, the couplings will not fit on the hub properly.

⚠ WARNING

Failure to observe the following warnings could create a risk of death or serious injury.

Contact with moving parts and/or rotating shafts poses a risk of serious injury. Proper guards in accordance with OSHA and American Society of Mechanical Engineers standards must be installed on all power transmission equipment. Power transmission equipment should not be started if proper guarding is not in place. Observe all required lock out/tag out procedures when servicing power transmission equipment.

TABLE 1. HIGH-PERFORMANCE SPLIT COVER TIGHTENING TORQUE

Coupling Series	Bolts in.	Tightening Torque
		Nm ft.-lbs.
QF15HPCOVER	(4) ¼ nc x 7/8	10.8 8
QF25HPCOVER	(4) 3/8 nc x 1¼	40.7 30
QF50HPCOVER	(4) ½ nc x 1¾	101.7 75
QF100HPCOVER	(4) ½ nc x 2¼	101.7 75
QF175HPCOVER	(4) 5/8 nc x 2½	169.5 125
QF250HPCOVER	(4) ¾ nc x 2¼	203.4 150
QF500HPCOVER	(4) ¾ nc x 2¼	203.4 150

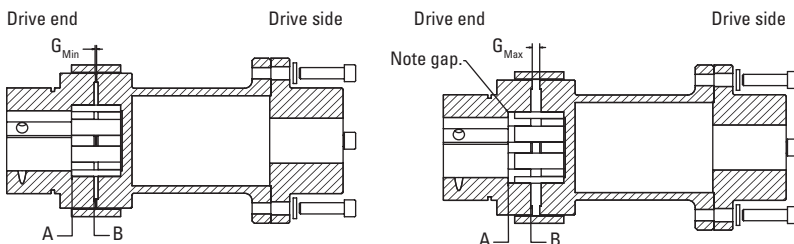

Fig. 2. Proper shaft-to-hub engagement.

REVOLUTIONS PER MINUTE (RPM) AND BALANCE

The Timken Quick-Flex coupling is machined on all surfaces and thus its dynamic balance is good. If the coupling is run at a high speed, it is important that the key used to attach the coupling hubs is the same length as the coupling hub. The set screws should also be changed to full length to fill the hole. Please refer to table 4 for maximum RPM ratings.

TABLE 2. QUICK-FLEX SINGLE-ENDED SPACER COUPLING HUB GAP (G) DIMENSIONS

Coupling Series	High-Speed Cover		Low-Speed Split Cover		High-Speed Split Cover		High-Performance Split Cover	
	G _{Min}	G _{Max}	G _{Min}	G _{Max}	G _{Min}	G _{Max}	G _{Min}	G _{Max}
	mm in.	mm in.	mm in.	mm in.	mm in.	mm in.	mm in.	mm in.
QF5	1.60 0.063	2.34 0.092	N/A	N/A	N/A	N/A	N/A	N/A
QF15	0.91 0.036	2.79 0.110	0.91 0.036	2.52 0.099	0.91 0.036	3.20 0.126	0.91 0.036	5.59 0.220
QF25	2.03 0.080	5.21 0.205	2.03 0.080	3.38 0.133	2.03 0.080	3.56 0.140	2.03 0.080	4.06 0.160
QF50	0.89 0.035	5.28 0.208	0.89 0.035	2.57 0.101	0.89 0.035	5.59 0.220	0.89 0.035	4.06 0.160
QF100	3.57 0.140	7.37 0.290	3.57 0.140	9.65 0.380	3.56 0.140	9.65 0.380	3.57 0.140	9.40 0.370
QF175	4.78 0.188	5.28 0.208	4.78 0.188	9.53 0.375	4.78 0.188	8.84 0.348	4.57 0.180	9.35 0.368
QF250	2.54 0.100	5.84 0.230	2.54 0.100	9.27 0.365	2.54 0.100	6.35 0.250	2.54 0.100	8.08 0.318
QF500	3.18 0.125	6.35 0.250	N/A	N/A	3.18 0.125	9.53 0.375	3.18 0.125	9.53 0.375
QF1000	4.06 0.160	9.86 0.388	N/A	N/A	4.06 0.160	10.41 0.410	N/A	N/A
QF1890	5.13 0.202	7.06 0.278	N/A	N/A	5.13 0.202	11.53 0.454	N/A	N/A
QF3150	1.79 0.070	7.75 0.305	N/A	N/A	1.78 0.070	9.65 0.380	N/A	N/A
QF10260	3.23 0.127	12.83 0.505	N/A	N/A	3.23 0.127	12.50 0.492	N/A	N/A

NOTE

Shaft should penetrate to base of teeth and hubs should be set at G_{Min}. Otherwise, the coupling may not deliver maximum torque.

TABLE 3. QUICK-FLEX SINGLE-ENDED SPACER COUPLING MISALIGNMENT TOLERANCES

Coupling Series	Radial Misalignment Tolerance	Axial Misalignment Tolerance	Angular Misalignment Tolerance
	mm in.	mm in.	
QF5	0.51 0.020	1.98 0.078	2°
QF15	0.99 0.039	2.95 0.116	2°
QF25	0.99 0.039	2.95 0.116	2°
QF50	0.97 0.038	2.95 0.116	2°
QF100	1.47 0.058	3.96 0.156	2°
QF175	1.47 0.058	4.45 0.175	1.3°
QF250	1.47 0.058	5.94 0.234	1.3°
QF500	1.47 0.058	5.94 0.234	1°
QF1000	1.47 0.058	5.94 0.234	1°
QF1890	1.47 0.058	7.92 0.312	1°
QF3150	1.98 0.078	7.92 0.312	1°
QF10260	1.98 0.078	7.92 0.312	1°

TABLE 4. QUICK-FLEX SINGLE-ENDED SPACER COUPLING MAXIMUM RPM RATINGS⁽¹⁾

Coupling Series	High-Speed Cover	Low-Speed Split Cover	High-Speed Split Cover	High-Performance Split Cover
	RPM	RPM	RPM	RPM
QF5	12000	N/A	N/A	N/A
QF15	9000	400	9000	9000
QF25	7000	375	7000	7000
QF50	6000	350	6000	6000
QF100	4800	300	4800	4800
QF175	4200	250	4200	4200
QF250	3800	200	3800	3800
QF500	3400	N/A	3400	3400
QF1000	3000	N/A	3000	3000
QF1890	2400	N/A	2400	2400
QF3150	2000	N/A	2000	2000
QF10260	1200	N/A	1200	1200

⁽¹⁾Maximum RPM ratings are for off-the-shelf Quick-Flex couplings. If your application requires higher RPM ratings, the couplings should be dynamically balanced.

TIMKEN

The Timken team applies their know-how to improve the reliability and performance of machinery in diverse markets worldwide. The company designs, makes and markets high-performance steel as well as mechanical components, including bearings, gears, chain and related mechanical power transmission products and services.

www.timken.com

T00371 0413

Stronger. **Commitment.** Stronger. **Value.** Stronger. **Worldwide.** Stronger. **Together.** | Stronger. **By Design.**